

# **IQ – pellet heating**

**See the difference !**

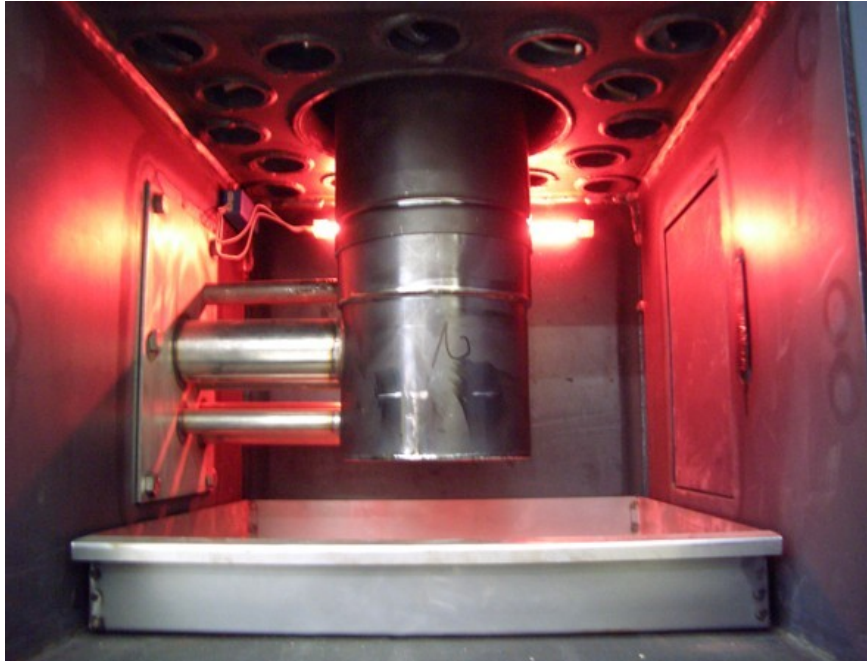

## What is your advantage with the SOLARvent – partition burner ?

### Answer:

### ***3-way air-distribution !***

***The accurate amount of air who is needed for the perfect burning process is put into the burner on the right place, in the right time, and in accordance to the quality of the fuel. The air is always there, where it is really needed.***

***With this legal protected innovation, SOLARvent-partition burners reach highest efficiencies during the entire burning prozess, with even no losses by down-modulating ! (4 kW – more than 95 % efficiency)***

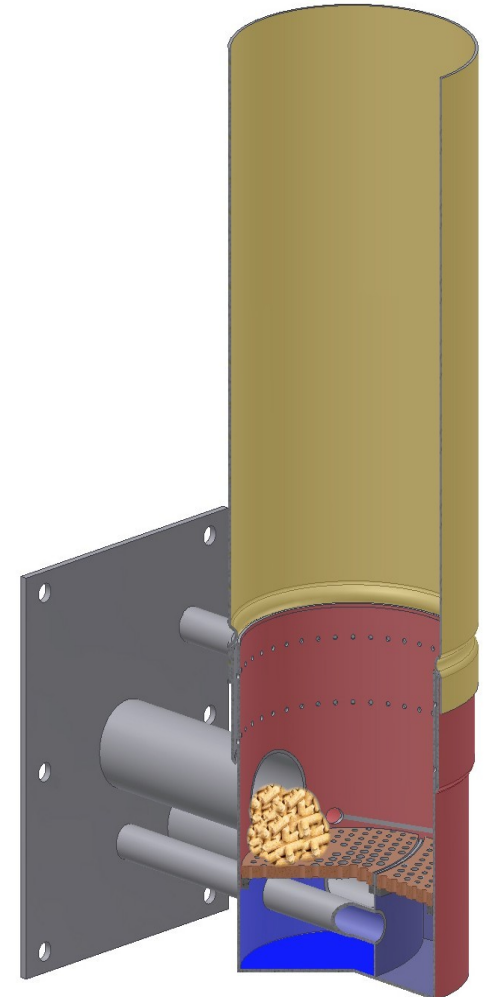

# Construction of the IQ - partition burner

**SOLARvent**<sup>®</sup>

Biomasse-Heizsysteme GmbH

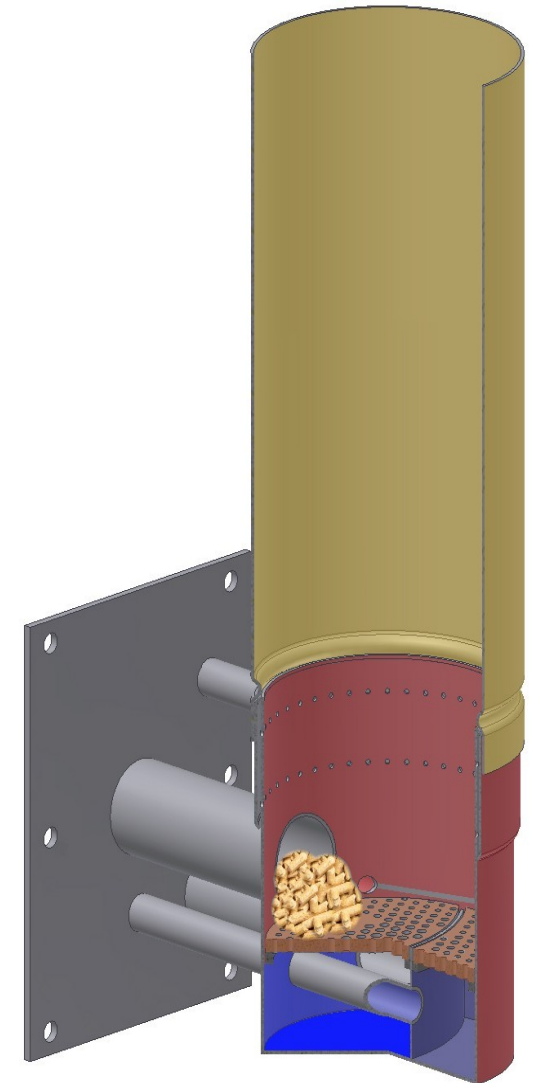
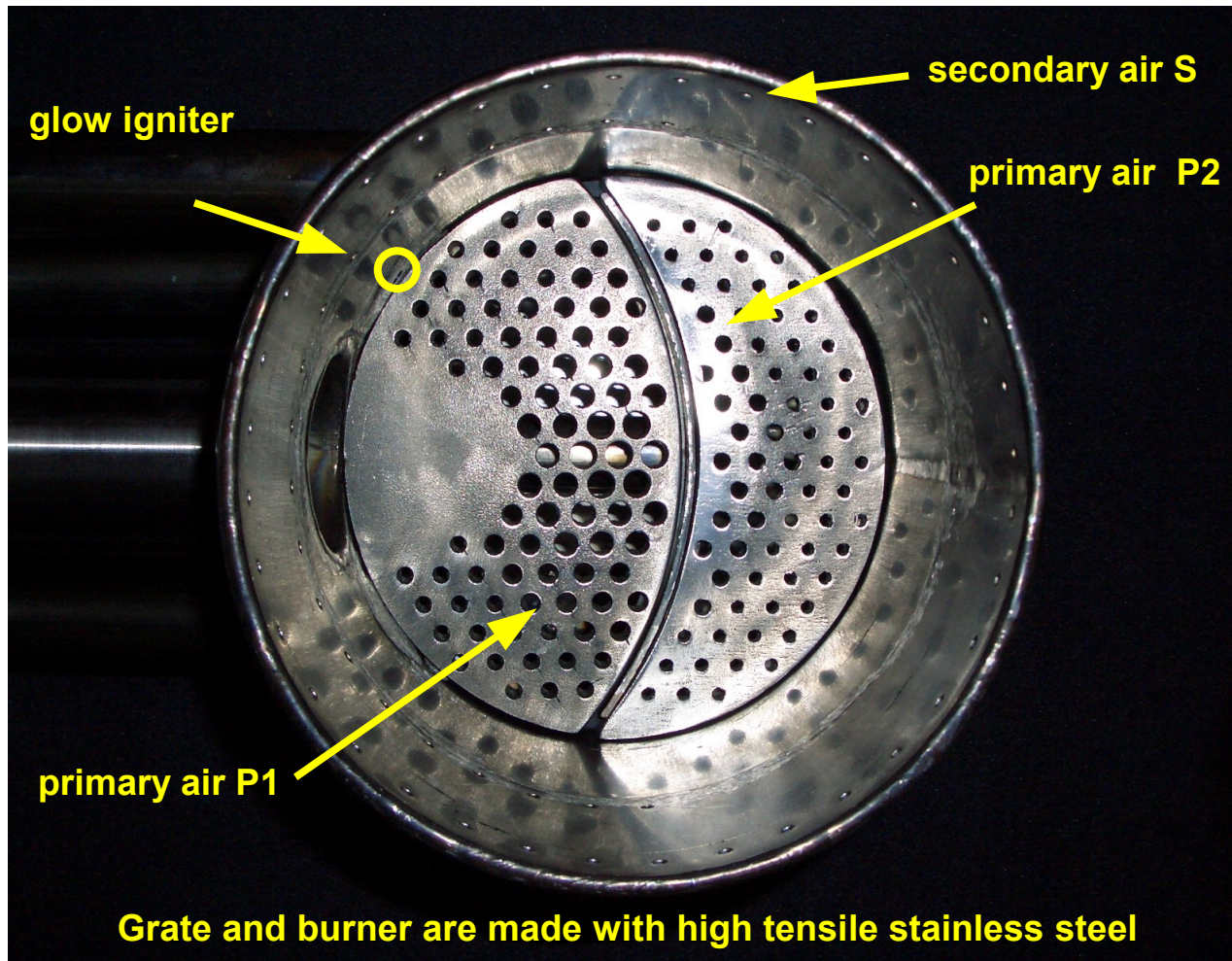

# Functionality: IQ – partition burner

**SOLARvent**<sup>®</sup>

Biomasse-Heizsysteme GmbH

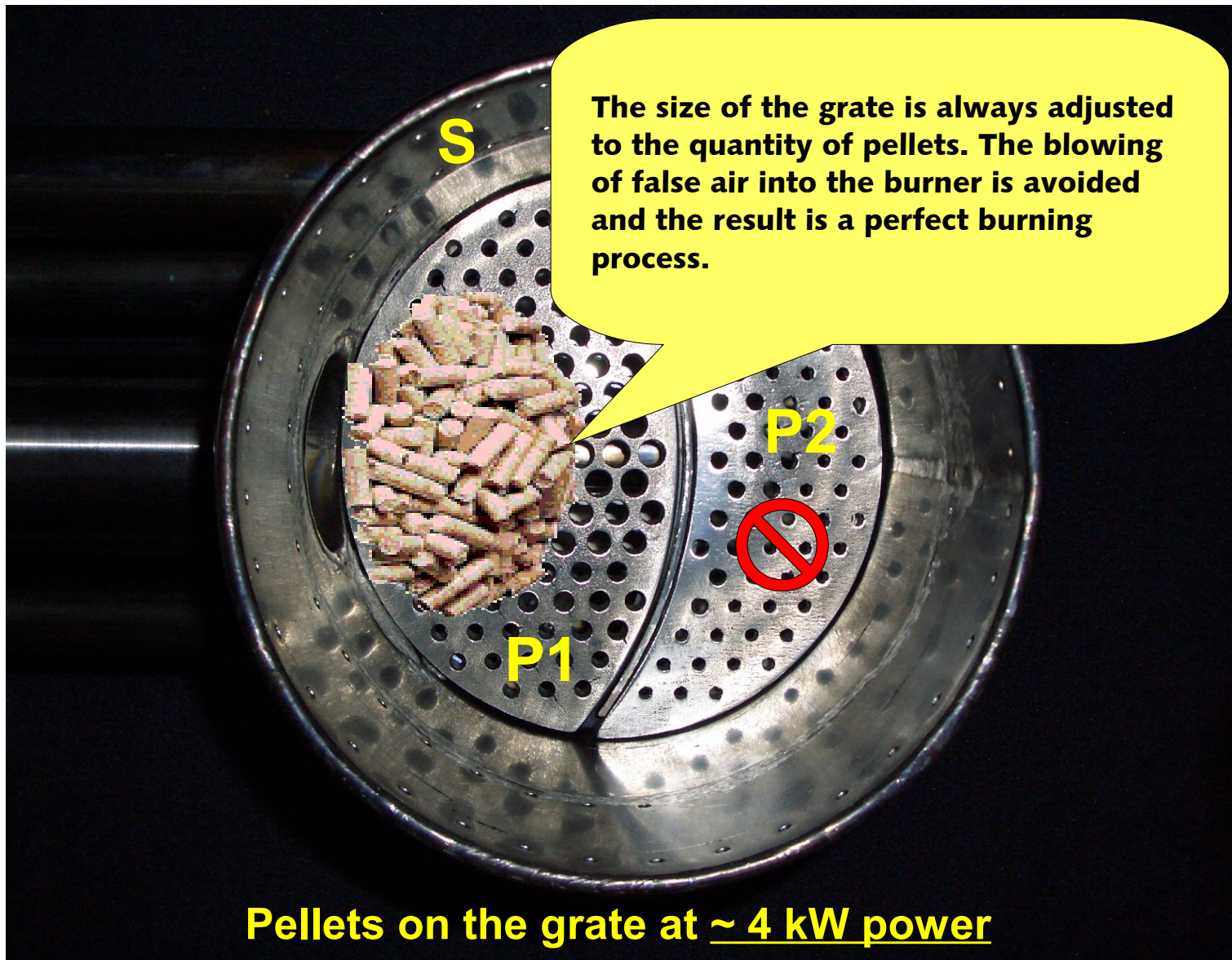

# Functionality: IQ – partition burner

**SOLARvent**<sup>®</sup>

Biomasse-Heizsysteme GmbH

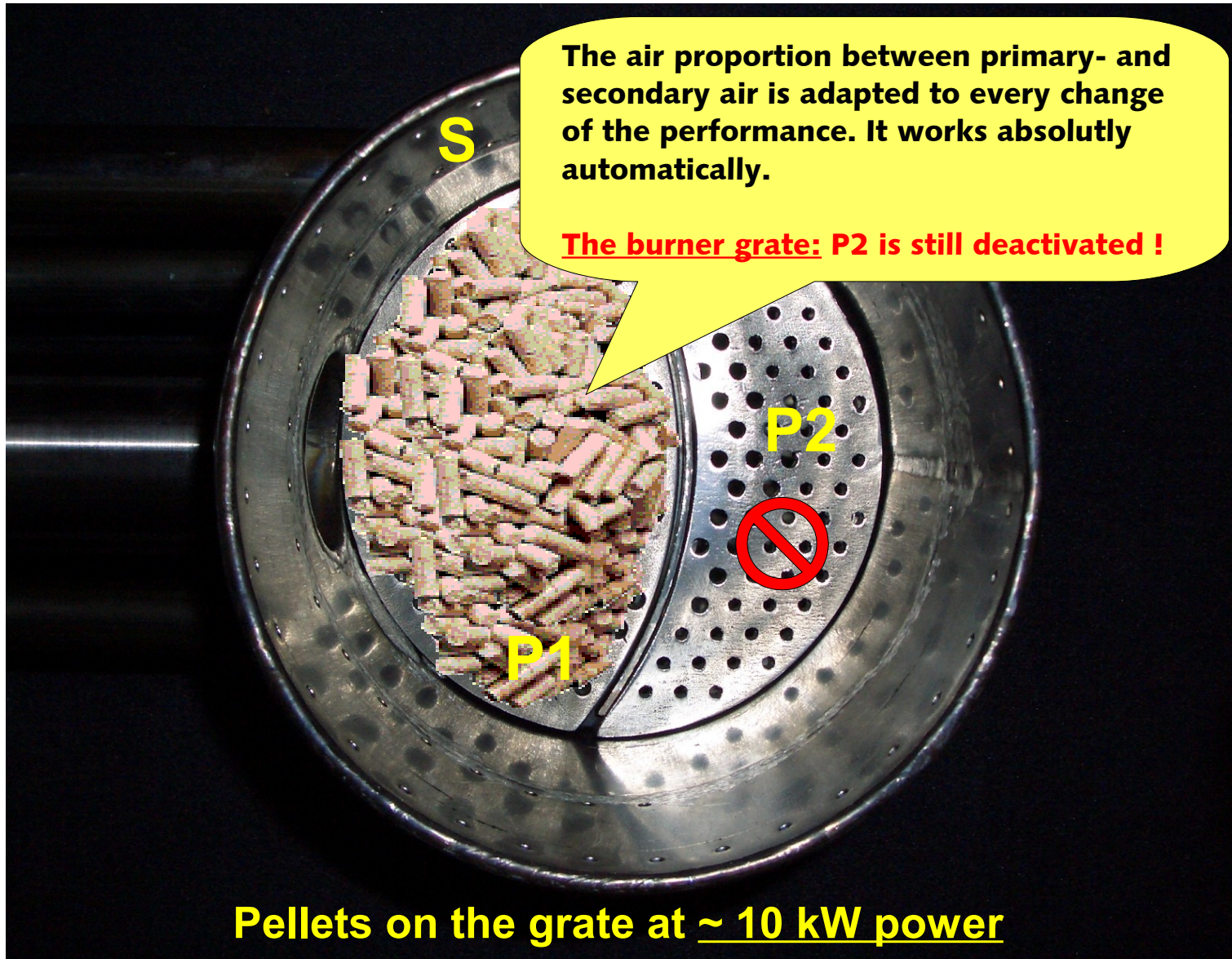

**Pellets on the grate at ~ 10 kW power**

# Functionality: IQ – partition burner

**SOLAR**vent®

Biomasse-Heizsysteme GmbH

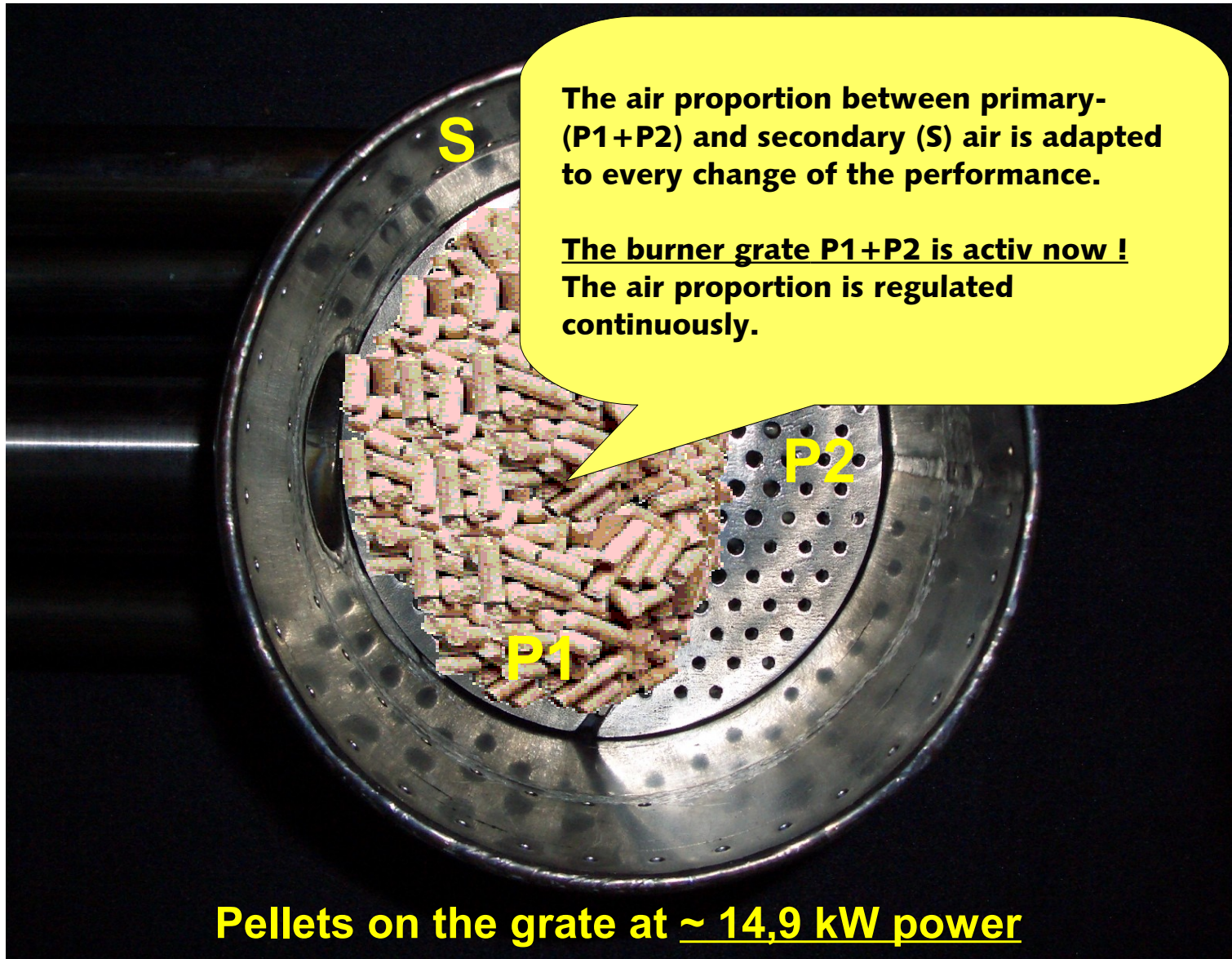

**Functionality:**  
**IQ – partition burner**

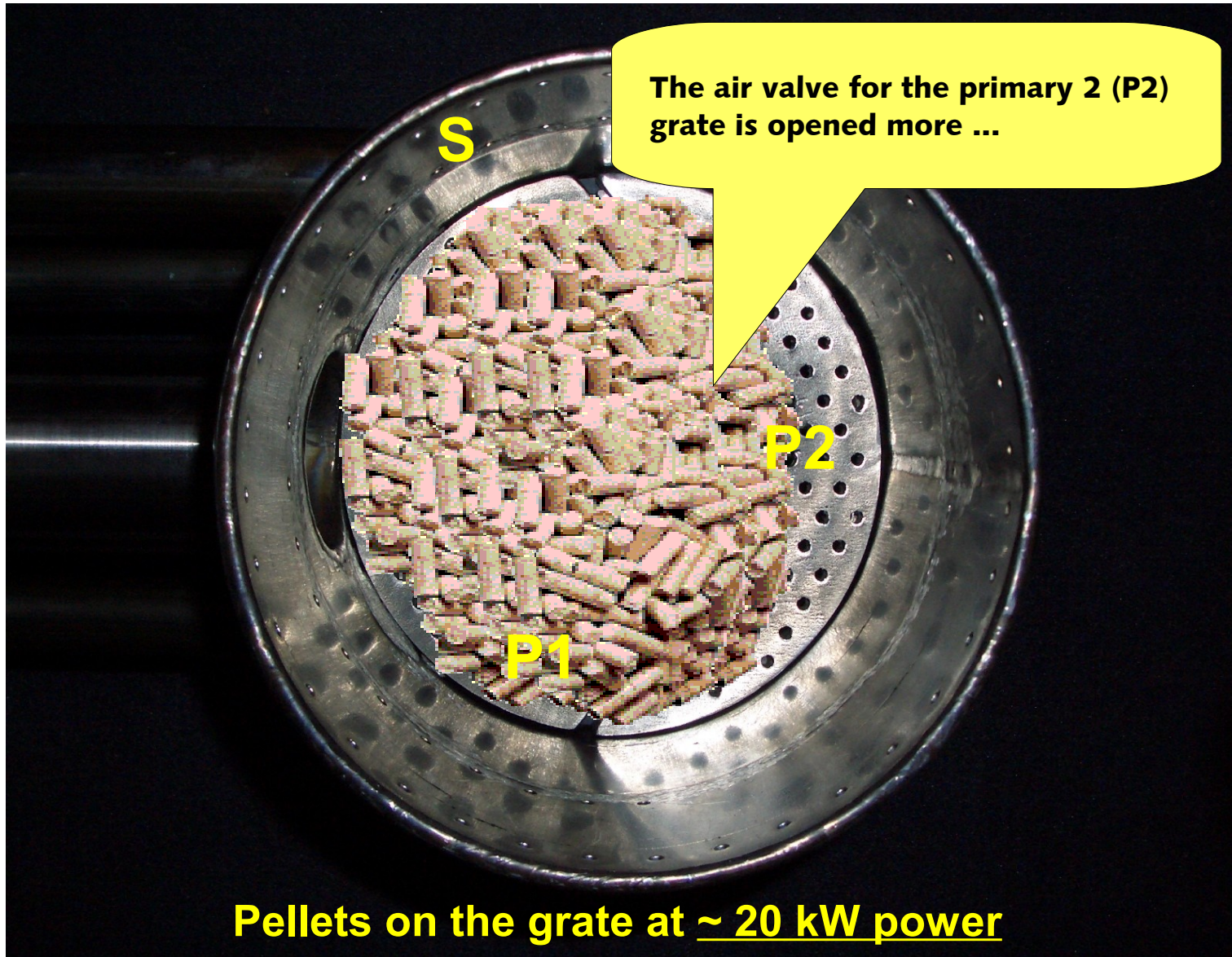

The air valve for the primary 2 (P2) grate is opened more ...

**Pellets on the grate at ~ 20 kW power**

# Functionality: IQ – partition burner

# SOLARvent®

Biomasse-Heizsysteme GmbH

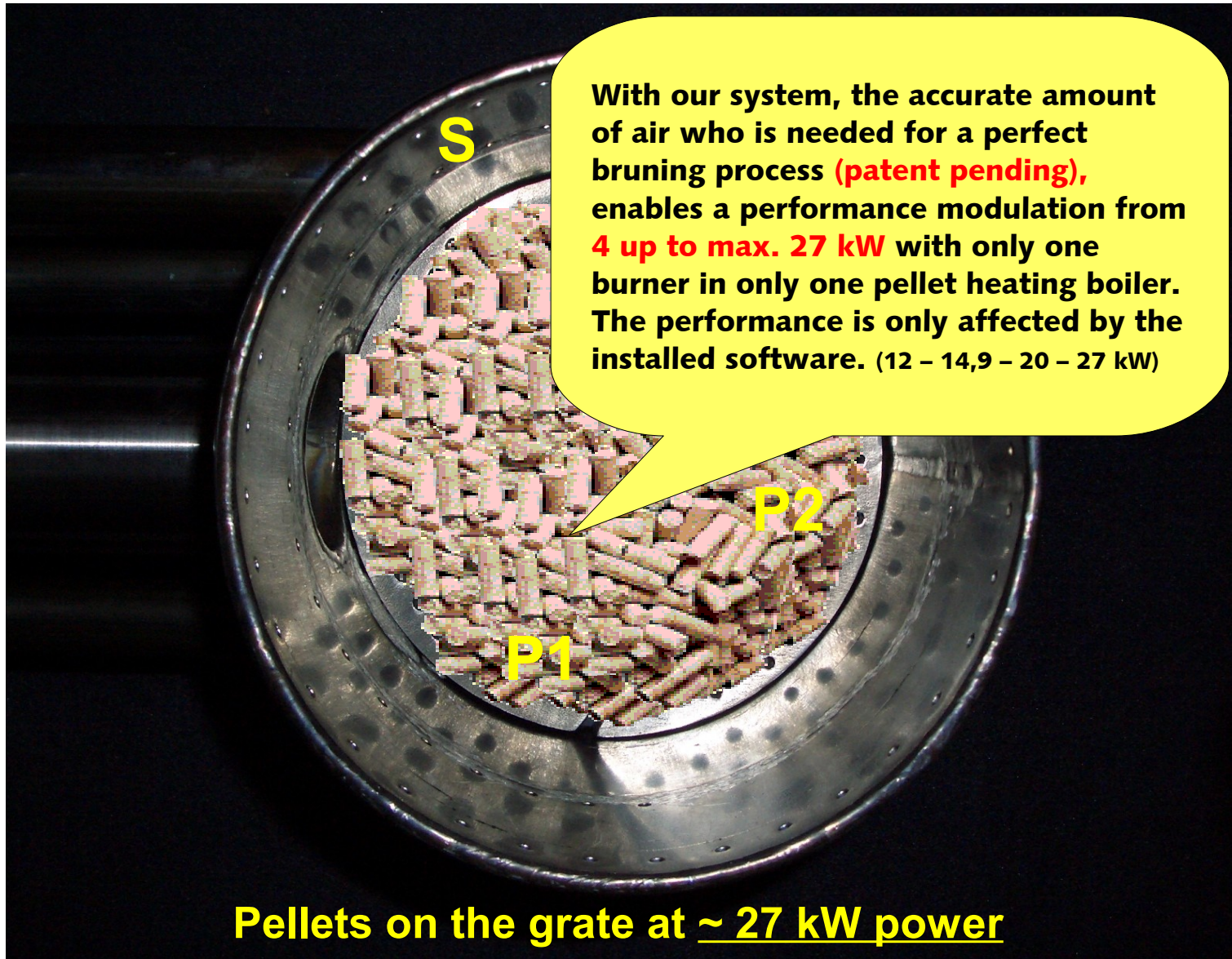

# Construction: 3-way air sharing

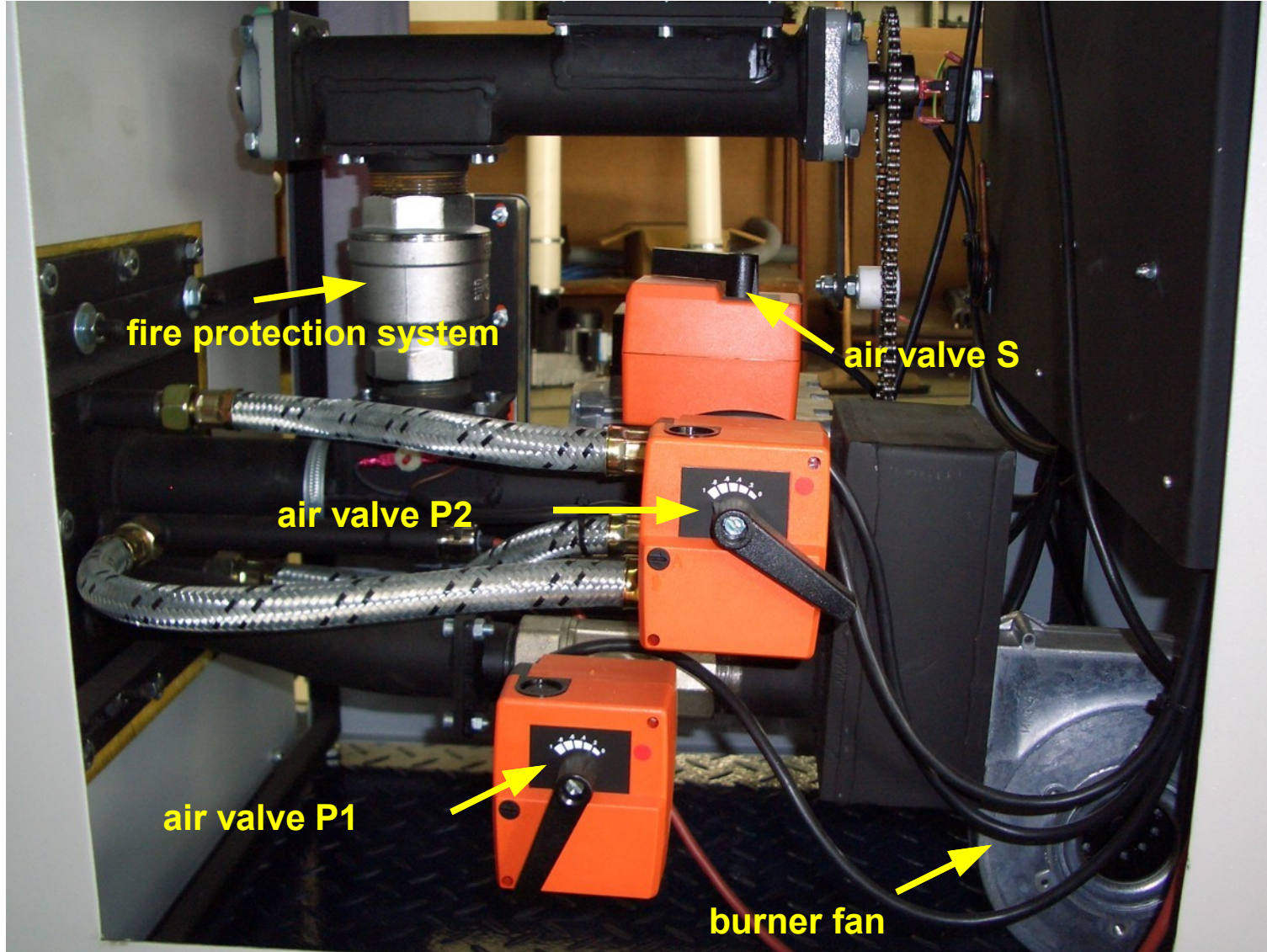

# Construction: pellet screw / fire protection system

# SOLARvent®

Biomasse-Heizsysteme GmbH

